

INSTALLATION AND OPERATION MANUAL

Cooney Smart Coil™

BOOT CLIP CONFIGURATION **VERSION 2.0**



TABLE OF CONTENTS

INTRODUCTION	2
WHAT'S INCLUDED.....	2
WHAT'S YOU'LL NEED.....	2
QUICK START	3
GENERAL INSTALLATION OVERVIEW.....	3
KEY COMPONENTS	3-4
OVERVIEW.....	3
CONTROL BOX - FRONT PANEL & CIRCUIT BOARD.....	4
SMART COIL™ CLIP & SENSOR INPUT WIRES.....	5
INSTALLATION	6-10
CONTROL BOX.....	6
ATTACH SMART COIL™ CLIP SENSORS FREEZE BLOCK® VALVES.....	6
RUN WIRING FROM CONTROL PANEL TO SENSOR.....	6-7
SPlice SENSOR LEADS.....	7
CONNECT SENSOR WIRING TO TERMINALS.....	8
CONNECT BMS / BAS ALARM OUTPUT.....	8
CIRCUIT BOARD DIAGRAM.....	9
CONNECT POWER.....	10
OPERATION	11-12
APPLICATION OF POWER.....	11
POWER UP INDICATORS.....	11
SYSTEM RESET.....	11
SENSOR OPERATION.....	11
ZONE FAULT INDICATORS.....	11
GENERAL FAULT INDICATOR.....	12
OPTIONAL SEQUENCE OF OPERATION.....	12
BM ALARM STATE ACTUATION.....	12
TROUBLESHOOTING	13
PHOTO CONSULTATION.....	13
FUSe.....	13
AMP DRAW.....	13

INTRODUCTION

The Smart Coil™ System protects coils from freeze damage by monitoring Freeze Block® valves. If a valve releases fluid, the system triggers an alarm which can be used to shut the system down.

This guide explains how to install the Smart Coil™ sensors, mount and wire the control panel, and verify proper system operation.

What the System Does

- Monitors up to 30 (standard model) or 8 (mini model) Freeze Block® valves
- Detects a freeze-related valve discharge
- Provides local visual alarm and BAS alarm signal

Standard Alarm Actions

When a valve trip is detected in normal operation, the Smart Coil™ System will:

- Illuminate the internal LED for the specific fault zone
- Illuminate the red alarm lamp on the front panel
- Activate the alarm relay for Building Management System (BMS/BAS) *this does NOT send a signal*
- The alarm remains latched until the condition clears and the reset button is pressed

WHAT'S INCLUDED

1 Smart Coil™ Control Panel

- NEMA 4 enclosure
- Pre-wired front panel indicators & reset switch
- Circuit board with sensor, power, and BAS terminals

2 Smart Coil™ Sensors

- Waterproof snap-on sensor boots
- Stainless steel sensing tips
- Pre-installed leads

3 Mounting Hardware

- Brackets/screws for panel mounting

WHAT YOU'LL NEED

Tools

- Phillips & flat-head screwdrivers
- Drill & driver bits
- Wire cutters & strippers
- Small flat screwdriver (terminal blocks)

Electrical & Wiring Materials

- 18-AWG, 2-conductor plenum cable (CL3P recommended)
- Dolphin waterproof connector(s)
- Conduit and fittings sized for wiring run
- Sealant or duct seal for conduit moisture protection



QUICK START

GENERAL INSTALLATION OVERVIEW

1. Mount the Control Panel

Place near coil or AHU in an accessible, visible spot. Install conduit entry in a manner that avoids moisture entry.

2. Attach Smart Coil™ Sensors to Valves

Attach directly to the Freeze Block® valve.

3. Run Sensor Wiring

Use conduit. Seal openings to prevent condensation inside the panel.

4. Splice Sensor Leads

Use waterproof connectors. Provide strain relief within 12 inches.

5. Connect Sensor Wires in Circuit Board

- White to GND
- Black to Signal
- Press orange terminal tabs to insert conductors.

6. Connect BAS Alarm Output (if used)

Wire dry contacts to building management terminals (NO/NC as required).

7. Connect & Apply Power

Connect 120VAC (J1) or 24VAC (J10) power.

8. Reset System & Test Sensors

Press blue reset button to clear any startup alarm state. Dip Smart Coil™ sensor tip in water to confirm successful operation.

KEY COMPONENTS

Your Smart Coil™ System includes several major pieces that work together to detect Freeze Block® valve activation and alert your building automation system (BAS) or maintenance staff.

OVERVIEW

Control Panel

- NEMA 4 enclosure
- Front Panel Interface
- Circuit Board Assembly
 - Front Panel Block
 - Sensor Terminal Blocks
 - Building Management Block
 - Fuse

Smart Coil™ Sensor Assembly

- Pre-Assembled Clip & Sensor
- Waterproof rubber boot protects sensor from spray & condensation
- Stainless steel sensing tips detect freeze event
- Snaps onto Freeze Block® Valve
- Works on all Freeze Block® Valve sizes

CONTROL BOX

A NEMA 4-rated, sealed enclosure designed for mechanical rooms and air-handling environments. The enclosure protects all detection and control electronics from dust, spray, and condensation. The panel houses the front interface, circuit board, wiring terminals, and power entry.

Inside the Control Box contains the components below, front panel interface, circuit board, building management alarm block.

Front Panel Interface

Located on the face of the enclosure for easy visibility and manual reset:

Component	Function
Blue Reset Button	Resets alarm and resets system once condition clears
Green Power Light	Confirm system is energized and functioning
Red Alarm Light	Indicates a Freeze Block® valve has discharged

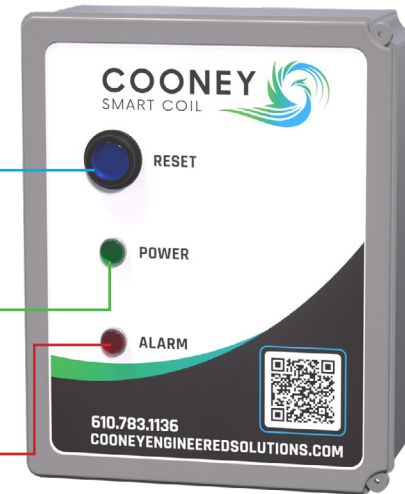

Circuit Board Assembly

Shown to the right, the circuit board is mounted to the metal mounting plate of the enclosure with four mounting screws and has the following functional blocks. (See wiring diagram on page 9-10)

FRONT PANEL BLOCK (J2)

Labeled J2, this 6 connector Screw Terminal block provides connectivity to the Front Panel features.

- Factory-wired connection to the front lights and reset button
- No field wiring needed here
- You get visual/alarm feedback without touching this block

SENSOR TERMINAL BLOCKS (J4-J9)

Sensor input area supporting up to 6 independent zones:

- 5 sensor pairs per zone
- 30 Smart Coil™ sensors maximum
- Spring-clamp terminals (push orange tab to insert wire)

POWER BLOCK (J1 OR J10)

The power block is a three conductor screw terminal which accepts Line, Neutral and Ground inputs, providing power to the Smart Coil™ System. Review voltage options.

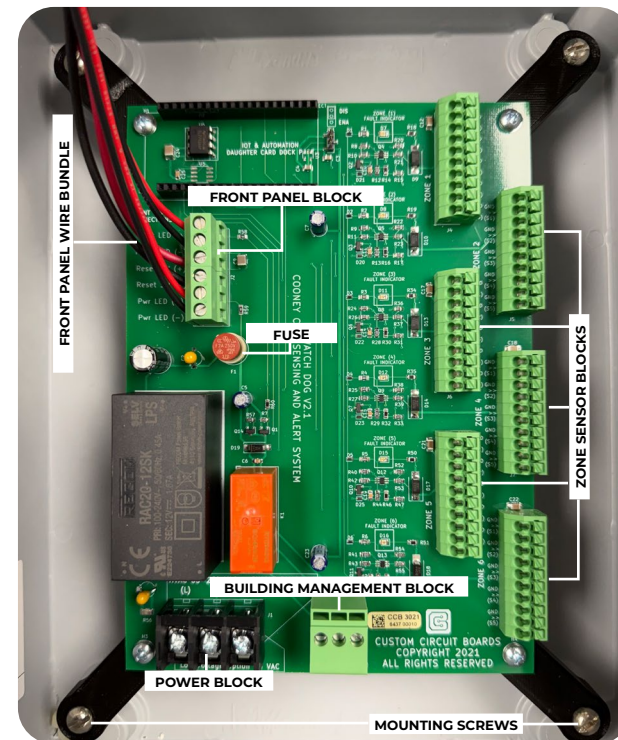

Circuit Board

BUILDING MANAGEMENT BLOCK

Dry-contact relay output for integration with BAS/BMS systems:

- Normally Open (NO) & Normally Closed (NC) terminals
- Low-voltage passive contact
- Changes state when any Freeze Block® valve deploys

This lets building controls trigger alerts, shutdowns, or notifications when freezing events occur.

FUSE (F1)

Onboard 12v DC power is protected from the AC input side via the 2A fuse labeled F1.

SMART COIL™ CLIP & SENSOR INPUT WIRES

Smart Coil™ Clip Assembly

The Smart Coil™ Clip is a snap-on sensor assembly designed to detect when a Cooney Freeze Block® valve discharges. It mounts directly to the valve head to monitor purge activity during a freeze event.

- Snap-on installation to Freeze Block® valve head
- Water-tight molded housing protects sensor from spray, condensation, and splash
- Stainless steel sensor tips detect water discharge instantly
- Compatible with all Cooney Freeze Block® valve sizes (2019 on)

This clip is engineered to reject false trips from drip or condensate, while reliably detecting a true purge event.



Sensor Input Wires

Each Smart Coil™ Clip includes two black leads. Splice these to the home-run field cable using waterproof connectors. The field wiring carries the signal back to the Smart Coil™ Control Panel through sealed conduit for alarm monitoring.



Recommended Wiring

- 18-AWG, 2-conductor plenum cable (CL3P)
- Solid or stranded acceptable

Wiring expectations

- Route wiring in conduit to protect from moisture and damage
- Make waterproof splices to the Smart Coil™ Clip leads (use Dolphin waterproof connectors)
- Install strain relief within 12 inches of the splice
- Keep wiring elevated and away from condensate pans and drip paths

INSTALLATION

1 MOUNT CONTROL BOX

Mount the control panel box in an accessible location, either inside or outside of the air handler, using the provided mounting hardware.

If you are mounting the control box outside of the air handler, cut a hole in air handler wall to run sensor leads through. The hole size will vary based on the number of leads.

Note: Avoid mounting the control box where condensation may drip directly onto the enclosure.

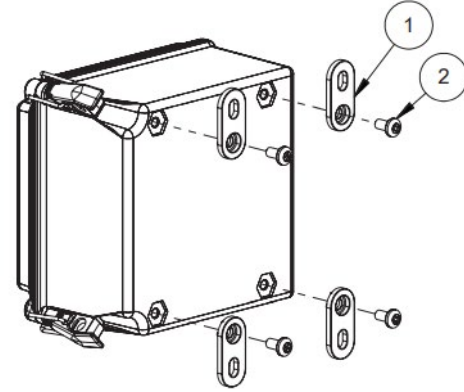

2 ATTACH SMART COIL™ CLIP SENSORS TO FREEZE BLOCK® VALVES

- Locate all Cooney Freeze Block® valves on the coil. Can be front AND back side of the coil.
- Ensure the valve design has a Smart Coil™ groove (anything purchased before 2019 will NOT have a groove and will need a updated valve style for Smart Coil™)
- Snap a Smart Sensor Assembly onto each valve hex head until fully seated.



3 RUN WIRING FROM CONTROL PANEL TO SENSOR

- Route wiring from each Smart Coil™ sensor to the control panel
- Use conduit for all home-run wiring
- Avoid routing conduit vertically into the top of the control box
- Seal conduit and panel entries to prevent moisture migration

The Smart Coil™ panel contains electronics sensitive to moisture. Proper conduit routing and sealing prevents nuisance alarms.

Conduit

Conduit should be used for home run wiring to the Control Panel with diameter and material dictated by the specifics of the installation.

The Control Panel is a NEMA 4 rated enclosure to prevent the entry of moisture to the internal sensing circuitry. The circuitry is very sensitive to moisture and the introduction of moisture inside the Sensor Panel can cause false trips and alarms.

For this reason, condensation and / or moisture buildup inside of a conduit line carrying sensor runs must be mitigated prior to entrance to the Sensor Panel.

This may be accomplished with the pathway chosen for the conduit approach to the Control Box. Conduit should not be run vertically into the top of the Control Box.

Some installation may require more advanced and appropriate sealing method such as:

- Seal-off fittings
- Expanding foam sealant
- Duct seal compound
- Mechanical seal

Application of moisture mitigation from conduit into the panel should be addressed by the installing contractor based on the specifics and environment of the installation site.

Wiring

18 AWG, 2 Conductor, Plenum Cable with CL3P Jacket for Security / Alarm / Access Control.

Braided vs Solid wire - Solid Conductor wire will provide a better insertion contact at the panel but both solid and braided are acceptable.

Shielded vs Non Shielded - The sensors have a very high noise tolerance and the use of shielding is not necessary. In this case, if shielded wire is used, the shield lines may be left disconnected at each end.

In a situation where home runs pass through high electrical noise environments, shielding may be accomplished inside the sensor panel by ganging the "shield wires" and connecting to the AC Ground Terminal. For this to be effective, the electrician needs to bring Ground to the panel as part of the AC installation. (Line, Neutral and Ground)

Strain Relief & Wiring Guidance

Within 12" of the Connection point joining the Home Run to the Smart Coil™ Sensor leads, strain relief should be provided.

All wiring should be secured off the floor or bottom surface where water may collect, as well as kept away from vertical condensation paths, drainage or dripping.

Finally, wiring should be secured out of catch points, walk ways, etc to keep moving equipment or personnel from snagging a loop or section of wire.

4 SPLICE SENSOR LEADS

- Splice Smart Coil™ clip leads to field cable using gel-filled, moisture-resistant connectors, B-type pigtail style, rated for 24-16 AWG conductors (insulated) and 16 AWG (stripped)
- Twist white + shield wires together for ground
- Black = signal
- Install strain relief within 12 inches of splice
- Secure wiring above floor and away from drip paths

Dolphin Super B Electrical Connector



5 CONNECT SENSOR WIRING TO TERMINALS IN THE CIRCUIT BOARD

Sensor Block

The sensor block includes six fault detection zones, each with a corresponding terminal connector:

- J4 – Zone 1
- J5 – Zone 2
- J6 – Zone 3
- J7 – Zone 4
- J8 – Zone 5
- J9 – Zone 6

Each terminal connector is used to wire the associated fault detection zone.

Each terminal connector includes 10 spring-tensioned wire inputs, arranged as Signal / Ground pairs. Each connector supports up to 5 sensor input cable pairs.

Connector labeling on the board identifies each pair as: GND >> S(n)

This indicates the corresponding ground and signal terminals for each sensor input.

To install sensor wiring:

1. Use a small flathead screwdriver to depress the orange spring tab
2. Insert the conductor fully into the terminal
3. Release the tab to secure the wire

Ensure conductors are fully seated and secure before proceeding.

Mini models only include two fault detection zones.

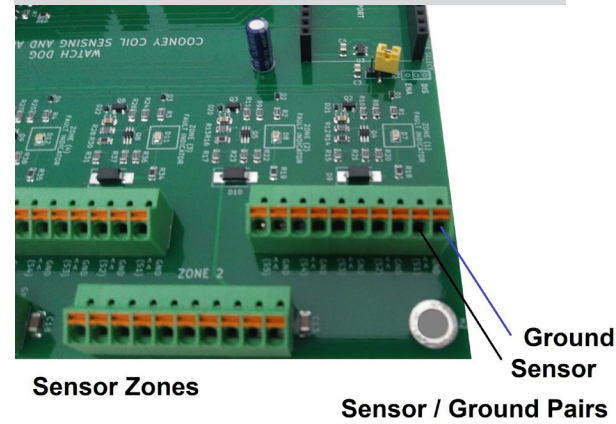

6 CONNECT BMS / BAS ALARM OUTPUT Building Management Block

A 3-conductor screw terminal block (J3) is provided for external monitoring. This terminal block is connected to a dry contact relay that changes state when an alarm condition occurs.

Terminal Configuration (Non-Alarm State):

- Pins 1 & 2: Normally Open (NO)
- Pins 2 & 3: Normally Closed (NC)

An alarm condition indicates that one or more valves have deployed. The output will remain in the alarm state until:

1. The fault condition has cleared, and
2. The reset button is manually pressed

Terminal Configuration (Alarm State):

- Pins 1 & 2: Closed
- Pins 2 & 3: Open

Electrical Rating:

- Passive dry contact, no internal power
- Maximum: 48 VAC/DC, 4 A
- Not fused, external protection required if needed

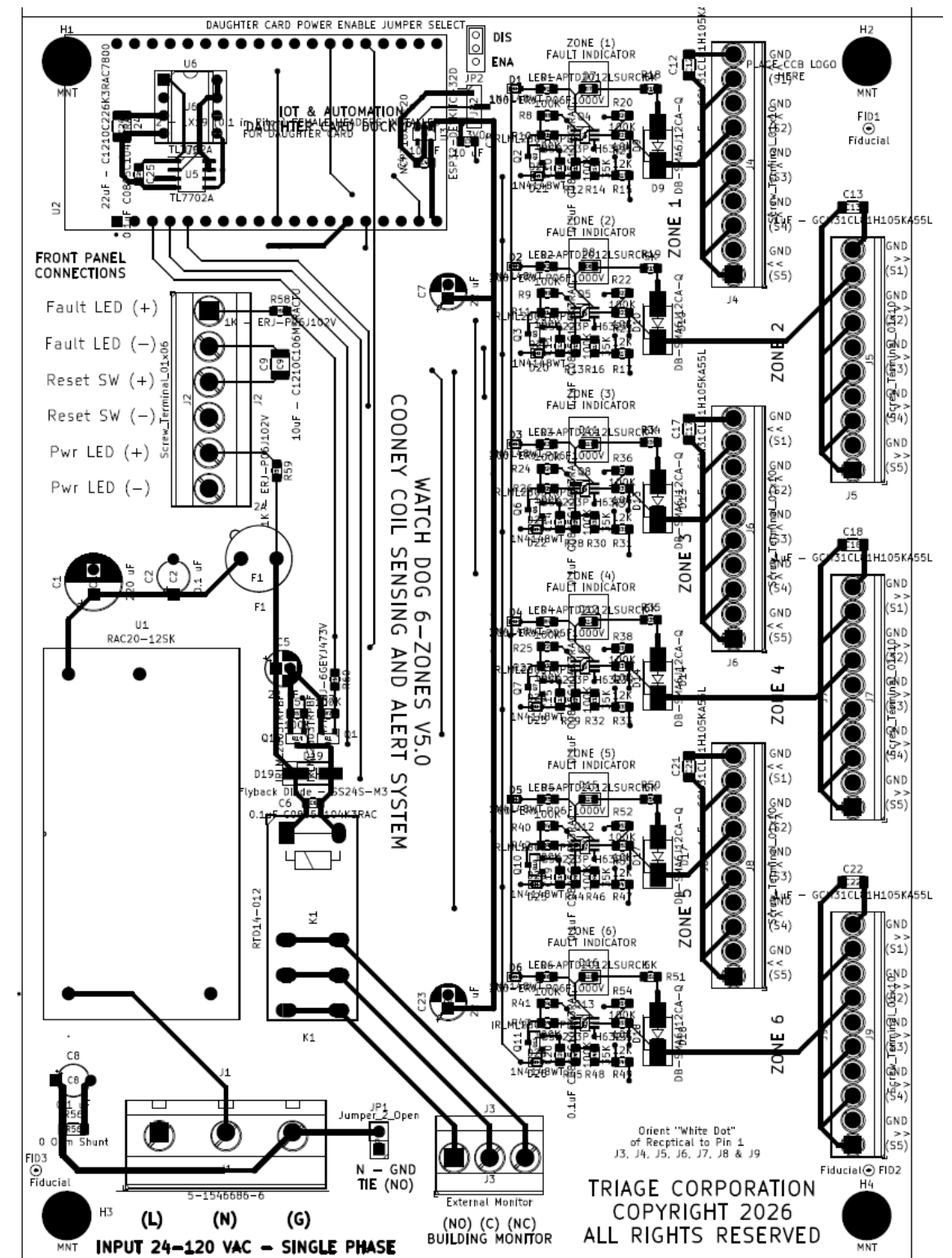

Circuit Board Diagram

Installation of BM wiring should enter the enclosure and be connected appropriately to the J3 terminal. Loosen the vertical screw of each terminal to allow for conductor placement, and then tighten the screw to compress and secure the wire conductor lead at each port. Do not over tighten the screw terminal. Snug torque is suggested.

7

CONNECT POWER

Power Block

The Smart Coil™ System can accept any voltage from 24VAC to 264VAC single phase.

First ensure that no power is applied to the supply input lines prior to working with these potentially dangerous conductors.

Connection should be made in all cases with Single Phase AC voltage using three conductor lines of Live, Neutral and Ground.

These should be installed to the associated screw terminal marked (L), (N) and (G) respectively.

Loosen the vertical screw of each terminal to allow for conductor placement, and then tighten the screw to compress and secure the wire conductor lead at each port.

Do not over tighten the screw terminal. Snug torque is suggested.

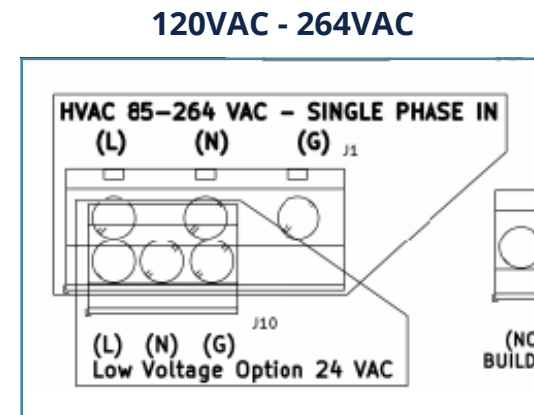

OPERATION

For a successful and smooth installation, first make a quick verification of proper connections to the Power Block, Sensor Block, BM Block and insure that the Unit is securely mounted. Following this review, complete the following steps to determine success of the installation.

APPLICATION OF POWER

At this time, power can be applied from the supply breaker panel.

POWER UP INDICATORS

Once power is supplied, you should observe the following state:

1. Front Panel Green Power lamp lit.
2. Front Panel Red Alarm lamp NOT lit.
3. Building Management Relay set to Alarm State.
4. Six LED Zone indicators on the PCB are NOT lit.

If this is not the condition, remove power and reassess the connections on the Front Panel Connector, Sensors and VAC.

SYSTEM RESET

If the Alarm Lamp is lit, press and release the Front Panel Reset Button once. This should cycle the system to Ready state which is summarized as:

1. Red Front Panel Alarm lamp is not lit.
2. Building Management Relay resets to Ready State.
3. Six LED Zone indicators on the PCB are not lit.

The system is now in Ready State, or Operational State.

SENSOR OPERATION

Sensor operation has three tiers of action with Zone Fault indicators, General Fault Indicator and BM Alarm State actuation. All of which should be verified.

ZONE FAULT INDICATORS

On the circuit board, you will note six zone fault indicators which are identified as Zone (1) Fault Indicator to Zone (6) Fault Indicator. These respectively match the six Sensor Blocks and are used to help narrow which zone(s) are at fault. Following system reset, these six indicators should not be illuminated. If one or more is illuminated there is a sensor fault being actively detected on the offending Zone.

ALARM FAULT

To reset the Alarm on the Smart Coil System, locate the Smart Coil control panel and press the reset button.

If the alarm does not reset, or goes right back into alarm, follow the steps below to determine root cause:

- Review all Freeze Block valve locations (potentially on both sides of the coil) to determine if any valves are actively deploying. If any valves are open and deploying water, the coil should be isolated to stop the fluid flow and then the alarm can be reset.
- Review Sensor leads and all connection points for proper installation per the IOM.
- Review circuit board for corrosion and damage
- If valves are not actively deploying, open the control panel and review the circuit board. Next to each terminal strip there is a small red LED that will be illuminated if a sensor within that terminal strip is in alarm. Determine which sensors are in fault by removing the sensors individually and then resetting the controller. Once the sensor(s) in fault are located within the control panel, trace them back to the respective Freeze Block valve location. Remove the clip / sensor and inspect for damage. Dry any moisture inside the clip, reinstall the clip/sensor on the valve and reset the control panel.

If alarm fault persists, remove the sensor from the terminal strip to clear the alarm and call the factory at 610-783-1136 for replacement parts.

POWER FAULT

If Green LED light on front of the panel is illuminated, power is supplied to the panel. If the Green LED light is not illuminated confirm the correct power is supplied to the panel.

GENERAL FAULT INDICATOR

As earlier mentioned, this is the Front Panel Red Lamp, which illuminates to indicate that one or more of the Zone Fault indicators has been triggered and that the system is in an Alarm State. A System Reset should clear this condition, also assuming that no Zones are in fault.

BM ALARM STATE ACTUATION

Finally, the Building Management output indicates the System state by toggling the relay condition which is connected to the BM Terminal Block.

As mentioned, in Ready State, continuity from (NO) to (C) is open circuit and (NC) to (O) is closed circuit.

During Alarm State, this continuity condition flips to indicate to the BM system that an Alarm

Condition exists; hence continuity from (NO) to (C) is now closed and (NC) to (O) is now open.

OPTIONAL SEQUENCE OF OPERATION

1. Shutdown Fan
2. Close Dampers
3. Preheat Coil Pump Activation
4. Send Alarm to BMS

TESTING SYSTEM FUNCTIONALITY

Following a System Reset, Ready and Alarm states can be induced for testing purposes with the following technique.

At one or more sensor inputs, dip the sensor end into a cup of water or squeeze the two leads simultaneously between a wet finger and thumb. This will simulate a Freeze Event / Valve Deployment and latch a fault in the associated Zone.

A latched fault will light the PCB Zone (n) Fault Indicator LED associated with the trip, Light the Red Front Panel Alarm lamp and toggle the Building Management Relay to Alarm State.

A Reset should clear this state and your installation is ready for Operation. It is suggested to conduct this test cycle on each Sensor line.

TROUBLESHOOTING

PHOTO CONSULTATION

After verifying the connection steps above, if standard operation is not achieved, take a photo of both the front panel and the control box inside. For the inside control box picture, be sure and include the back side of the front panel which includes the Front Panel Wire bundle as well as the circuit board.

With those two photos, make a call to our engineering support at (610) 783-1136 and email the photos to engineering@cooneycoil.com.

FUSE

If it appears there is no power to the Circuit Board, as in the case that power is applied and all seven fault indicators did not light, then it may be valid to check the 12 v dc 2A fuse. If there is a blown fuse, it is best to make a visual inspection to determine cause. When this condition is cured, a new fuse may be re-installed.

Replacement fuses can be commonly purchased from sources such as Digikey.

Replacement part number: 1 Fuse 2 Amp Fuse WK4957BK-ND Littlefuse

AMP DRAW

120V → .5 Amps

24V → 2.5 Amps

CONTACT US

For additional questions and engineering support contact us:

 (610) 783-1136

 engineering@cooneytechnologies.com



Scan to
register warranty

COONEY SMART COIL™

FREEZE PROTECTION. PEACE OF MIND.

The Cooney Smart Coil™ System is engineered to help facility teams identify freeze events early and protect critical HVAC equipment with reliable, automated monitoring.

For support, installation guidance, or replacement parts contact us:

(610) 783-1136 | engineering@cooneytechnologies.com
20130 Valley Forge Circle | King of Prussia, PA 19406

